



a **molex** company

# PEX6-COP

V 1.7 03/21/23

PCI Express Desktop/Server Coprocessor with Virtex6 FPGA computing core and FMC IO site

## FEATURES

- Desktop/Server 3/4-length FPGA coprocessor card
- FMC I/O site (VITA 57) with x10 6.25 Gbps MGT lanes, 80 LVDS pairs (LA, HA, HB full support)
- **FPGA Computing Core**
  - Xilinx Virtex6 LX240T, SX315T or SX475T
  - 2 Banks of 256Mb x 32 DDR3 (2048 MB total)
  - 1 Banks of 256Mb x 16 DDR3 (512 MB total)
  - 2 banks of QDRII+ SRAM (4MB each, options to 18MB each)
  - 32Mb FLASH
- Dual sample clock inputs
- High speed trigger inputs support multi-card synchronization and coordinated sampling
- Gen2 x8 PCI Express providing 4 GB/s burst and 3.2 GB/s sustained transfer rates
- x4 Secondary Port usable as PCI Express or Aurora
- < 15W typical excluding FMC
- Configures from on-card FLASH
- Temperature monitoring
- High temperature option: 0 to +85C operation

## APPLICATIONS

- FPGA co-processing and acceleration
- Wireless Receivers – LTE, WiMAX, SATCOM
- RADAR, Signal Intelligence
- Medical Imaging
- High Speed Data Recording and Playback
- IP development

## SOFTWARE

- MATLAB/VHDL FrameWork Logic
- VxWorks/Linux/Windows Drivers
- Microsoft and Codegear C++ Host Tools



(BGA cooler obscures FPGA)

## DESCRIPTION

The PEX6-COP is a flexible FPGA co-processor card that integrates a Virtex6 FPGA computing core with an industry-standard FMC IO module on a three-quarter-length PCI Express desktop or server card.

The FPGA computing core features the Xilinx Virtex 6 FPGA family, in densities up to the SX475. The SX475 provides over 2000 DSP MAC elements operating at up to 500 MHz. The FPGA core has two QDRII+ SRAM banks and five 512 MB DDR3 DRAM banks. Each memory is directly connected to the FPGA and is fully independent.

For system communications, the PEX6-COP has a PCI Express and a secondary x4 port. The PCIe port is a x8, Gen2 interface capable of up to 3.2 GB/s sustained operation with 4 GB/s burst rate. The secondary port can be used as Aurora ports (x4 to x1), as a second PCI Express x4 port, or using a custom protocol.

An FMC site, conforming to VITA 57, provides configurable IO for the PEX6-COP. The FMC site has full support for the high pin count connector, with over 80 LVDS pairs directly connected to the FPGA and x10 lanes at up to 6.25 Gbps per lane. FMC also is readily adapted to application-specific custom modules.

The PEX-COP family power is less than 15W for typical operation. The card is available rated for wide-temperature (-40 to +85C) and 100% humidity with conformal coating.

The FPGA logic can be fully customized using the Frame Work Logic tool set. The toolset provides support for both MATLAB and RTL designs. The MATLAB BSP supports real-time hardware-in-the-loop development using the graphical, block diagram Simulink environment with Xilinx System Generator. IP cores for a range of signal processing cores for applications such as wireless, RADAR and SIGINT such as DDC, demodulation, and FFT are also available.

Software tools for host development include C++ libraries and drivers for Windows and Linux (including real-time variants). Application examples demonstrating the module features are provided.



Please be aware that an important notice concerning availability, standard warranty, and use in critical applications of Interconnect Systems International, LLC, Inc. products and disclaimers thereto appears at the end of this data sheet. All trademarks are the property of their respective owners.

PRODUCTION DATA information is current as of publication date. Products conform to specifications per the terms of the Interconnect Systems International, LLC, Inc. standard warranty. Production processing does not necessarily include testing of all parameters.

©2007 Innovative Integration • phone 805.578.4260 • fax 805.578.4225 • www.innovative-dsp.com



# PEX6-COP

## ORDERING INFORMATION

Product	Part Number	Description
PEX6-COP	80284-1-<ER>	FPGA coprocessor for desktop/server PCI Express with FMC IO site; Xilinx LX240T FPGA -2 speed grade supporting x8 Gen2 PCI Express. 2 x 4MB SRAM, 5 x 512MB DDR3 DRAM. <ER> is environmental rating (see following table)
	80284-3-<ER>	Like 80280-1 except SX315T2 FPGA
	80284-6-<ER>	Like 80280-1 except SX475T2 FPGA
PEX6-COP FrameWork Logic	55038	PEX6--COP FrameWork Logic board support package for RT. Includes technical support for one year. Check with sales for specific FMC support.
Software	57001	Malibu software installation DVD including drivers for Windows and Linux.

## PEX6-COP

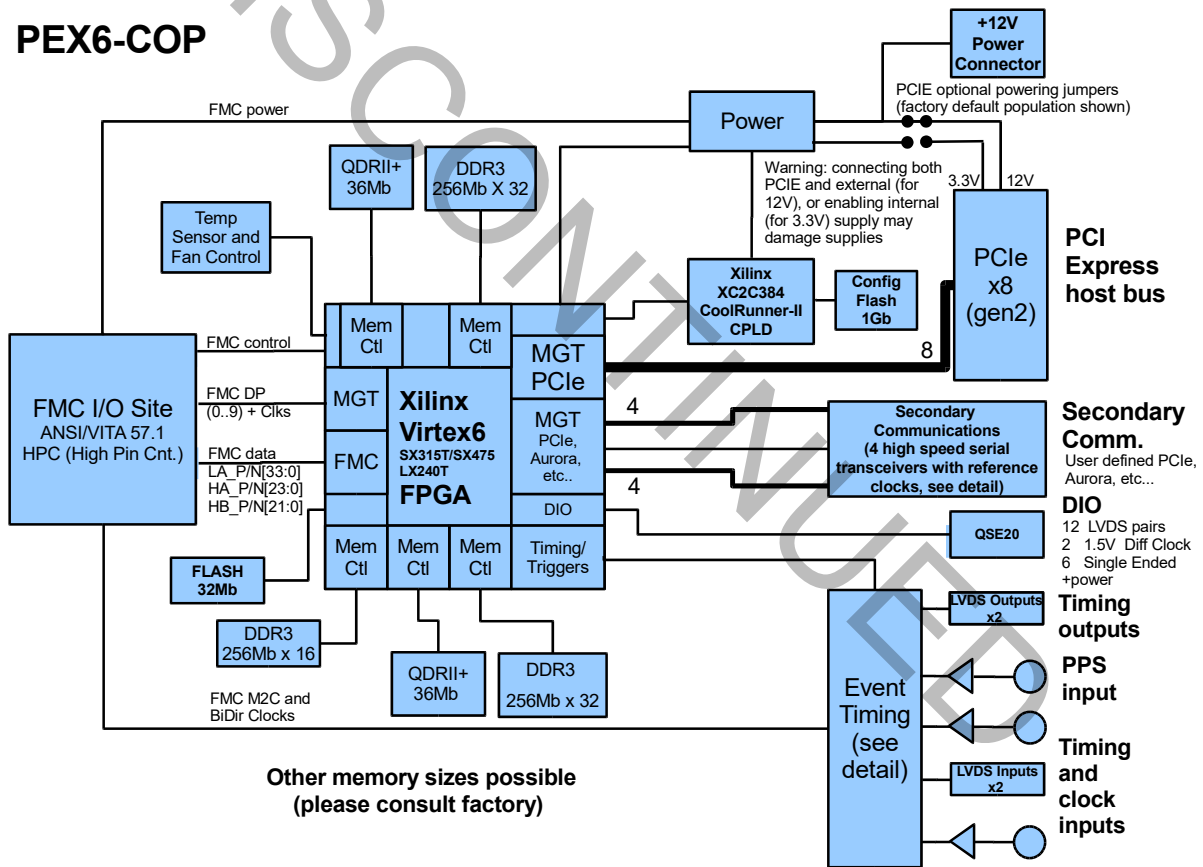

Illustration 1: Block Diagram

# PEX6-COP

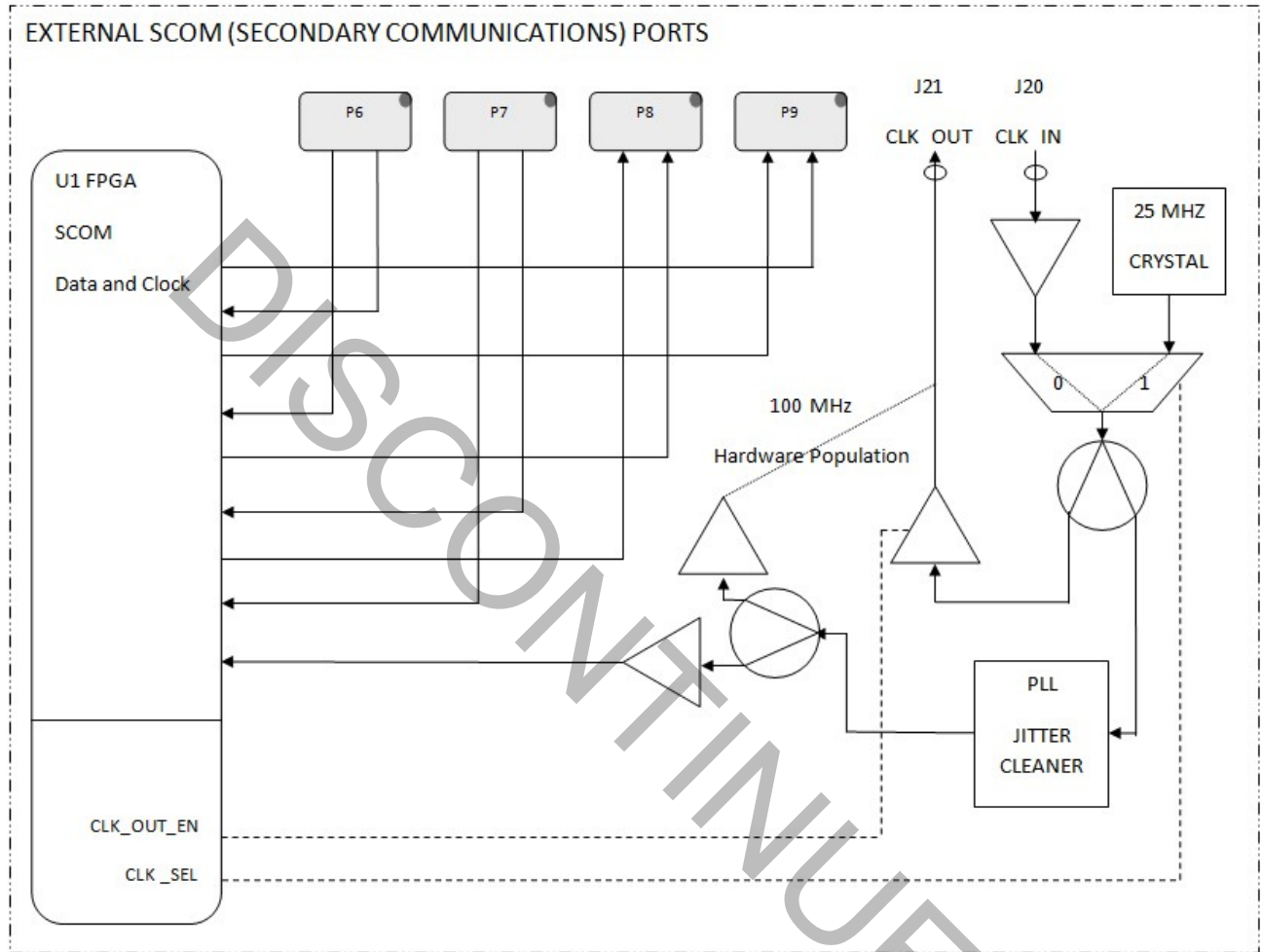

Illustration 2: External Serial Communications Ports (x4)

# PEX6-COP

FMC Event timing (Data Acquisition Triggers with bidirectional FMC clocks 2 and 3) circuits were added.

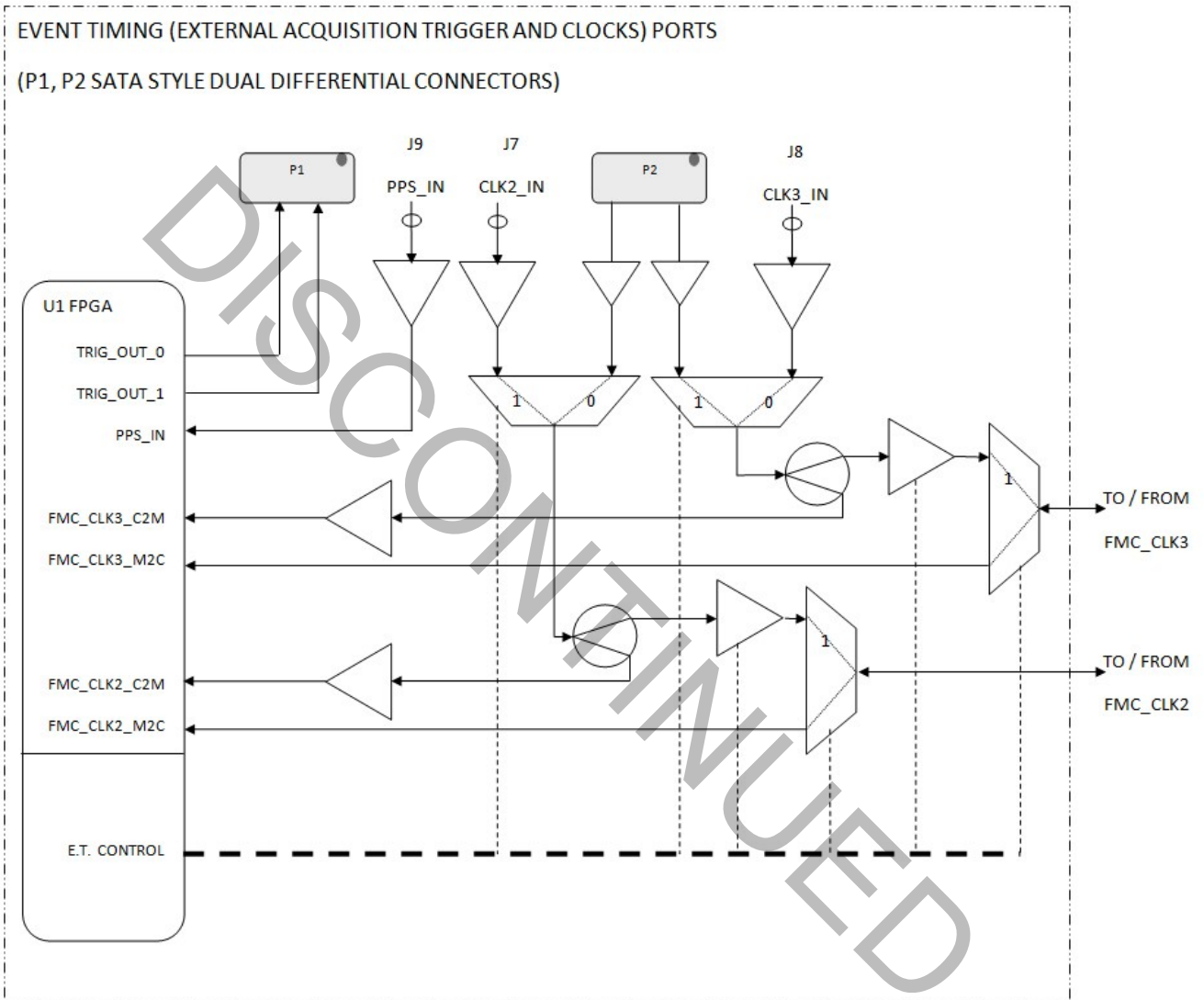

Illustration 3: Event Timing Detail

# PEX6-COP

## Operating Environment Ratings

The PEX6-COP and FMC modules are available for wider temperature operation. The cards are 100% tested for operation over the specified range.

Environment Rating <ER>		L0	HT
Environment		Office, controlled lab	Outdoor, stationary
Applications		Lab instruments, research	Outdoor monitoring and controls
Cooling		Forced Air 20 CFM	Forced Air 20 CFM
Operating Temperature		0 to +50C	0 to +85C
Storage Temperature		-20 to +90C	-40 to +100C
Vibration	Sine	-	-
	Random	-	-
Shock		-	-
Humidity		0 to 95%, non-condensing	0 to 95%, non-condensing
Testing		Functional, Temperature cycling	Functional, Temperature cycling, Wide temperature testing

Minimum lot sizes and NRE charges may apply. Contact sales support for pricing and availability.

For rugged applications with vibration and shock, the VPX6-COP, a 3U VPX version of the PEX6-COP, is available rated up to 40G and 0.1g<sup>2</sup>/Hz vibration.

# PEX6-COP

## Standard Features

FMC Site	
Specification	VITA 57 FMC
Type	High Pin Count
High Speed Pairs	10 lanes (Tx/Rx pair) 6.25 Gbps max rate
Signal Pairs	80 pairs total LA: 33 pairs (Vcco = 2.5V, Vref from FMC) HA: 24 pairs (Vcco = 2.5V, Vref from FMC) HB: 22 pairs (Vcco and Vref from FMC)
IO Standards	LA, HA : LVCMOS25, LVDS25, LVDCI2, SSTL25, HSTL25 HB: all IO standards supported
Power	3.3V @ 3A (supplied by bus or on-card supply) 12V @ 1A (supplied by bus) 3.3V AUX @ 0.5A (supplied by bus) Vadj = 2.5V @ 4A (programmable)

FPGA	
Device	Xilinx Virtex6
Speed Grades	-2, (-1 special order) <b>-2 required for PCI Express x8 Gen2</b>
Sizes	SX315T = ~ 31M gates equivalent SX475T = ~ 47.5M gates equivalent LX240T = ~ 24M gates equivalent
Flip-Flops /Slices	SX315T: 393K /49K SX475T: 595K / 74K LX240T: 301K / 37K

DSP48E1 elements/ BlockRAMs	SX315T: 1344 / 704 SX475T: 2016 /1064 LX240T: 768 /416
GTP Ports	x8 lanes @ 6.25 Gbps (-3 speed) to PCIe x10 lanes @ 6.25 Gbps to FMC x4 lanes @ 3.2 Gbps to secondary COM ports
Configuration	JTAG or FLASH In-system reprogrammable

Memories	
DDR3 DRAM	DDR3: 256Mx16 512MB total/device Five devices available 400 MHz clock rate 3.2 GB/S burst transfers (400 MHz clock)
QDRII+ SRAM	8MB standard; 2 banks of 2Mx18 Options up to 16Mx18 per bank 333 MHz clock rate (standard device speed is rated for 400MHz, options up to 500 MHz) 4 GB/s sustained transfer rate (simultaneous read/writes using 500 MHz clock)
Program FLASH	Serial FLASH 32Mb SPI interface
Configuration FLASH	Parallel FLASH 1GB configures FPGA through CPLD loader

# PEX6-COP

Host Interfaces	
PCI Express	x8 Lanes Gen2 (requires -2 or -3 speed FPGA) x4 Gen2 or x8 Gen2 (-1 speed FPGA) x8 Gen2 supports 3.2GB/s sustained rates/4 GB/s burst rates
Secondary Ports	x4 lanes capable of 3.2 Gbps per lane Configurable as Aurora (4 x1 to 1 x4, PCI Express x4 , or custom protocols 4 SATA connectors for card-to-card connections

Sample Clocks and Triggering	
Clock Sources	2 SMA for FMC clocks 1 SMA for clock to FPGA
Trigger Sources	2 LVDS outputs (SATA-style connector) 2 LVDS inputs (SATA-style connector)
Timing Synchronization	2 multi-drop LVDS pairs 2 open-collector flags IDC10 connector, 2mm

Monitoring	
Alerts	Temperature Warning, Temperature Failure, Power Faults
Alert Timestamping	5 ns resolution, 32-bit counter

Application IO (P2)	
DIO Bits	32, arranged as 16 pairs
Signal Standards	LVC MOS (2.5V) – NOT 3.3 compatible LVDS25

Power	
Consumption	15W typical
Temperature Monitor	Software with programmable alarms
Over-temp Monitor	Disables power supplies
Power Control	LPDDR3 deep sleep mode QDR shutdown FMC power controls
Heat Sinking	Heat sink on FPGA Optional fan for FMC cooling

Physicals	
Form Factor	½ length PCI Express card
Size	8.2 x 3.8in (209 x 96 mm)
Weight	250 g (excludes FMC)
Hazardous Materials	Lead-free and RoHS compliant

# PEX6-COP

## Architecture and Features

The PEX6-COP architecture integrates a Xilinx Virtex6 FPGA computing core with an FMC module on a PCI Express desktop/server three-quarter-length card. System communications include a x8 Gen2 PCI Express port and a x4 secondary communications port. This architecture tightly couples the FPGA to the FMC and enables the module to perform real-time signal processing with low latency and extremely high rates. It is well-suited for FPGA co-processing and front-end signal processing applications in wireless, RADAR and medical imaging.

### FMC Module

The FMC module is a VITA57-compliant site for IO or system expansion. The FMC directly connects to the FPGA with 80 pairs of LVDS (160 single-ended) and 10 lanes of high speed serial. The serial lanes connect to the FPGA GTP ports.

FMC modules are integrated with the PEX6-COP by including application logic in the FPGA that provides interface control and data communications. The flexible nature of the FMC interface is also useful for custom application-specific where the pin use and interface are defined by the application logic.

### Clocks and Triggers

Support for FMC integration with system devices includes clock and trigger sharing features so that multiple cards can perform simultaneous or coordinated sampling. Simple inter-card connections supports trigger sharing through two LVDS input and two LVDS outputs. These trigger signals are provided on SATA-style connectors and support speeds up to 1 GHz.

Integration with a system timing card such as X3-Timing allows the cards to use common sample clocks and triggers, coordinated with GPS or another system reference.

### FPGA Core

The PEX6-COP family has a Virtex6 FPGA and memory at its core for DSP and control. The Virtex6 FPGA is capable of over 1 Tera MACs (SX315T operating at 500 MHz internally) with over 1300 DSP elements in the SX315T FPGA. In addition to the raw processing power, the FPGA fabric integrates logic, memory and connectivity features that make the PEX6-COP capable performing very demanding real-time signal processing.

The FPGA has direct access to five banks of 512 MB of DDR3 DRAM and two banks of QDRII+ SRAM. These memories allow the FPGA working space for computation, required by DSP functions like FFTs, and bulk data storage needed for system data buffering and algorithms like large FFTs. A multiple-queue controller component in the FPGA implements multiple data buffers in the DRAM that is used for system data buffering and algorithm support. The SRAMs provide fast access for algorithm. The DDR3 is compatible with embedded processors (uBlaze).

The PEX6-COP uses the Virtex6 FPGA as a system-on-chip to integrate all the features for highest performance. As such, all IO, memory and host interfaces connect directly to the FPGA – providing direct connection to the data and control for maximum flexibility and performance. Firmware for the FPGA completely defines the data flow, signal processing, controls

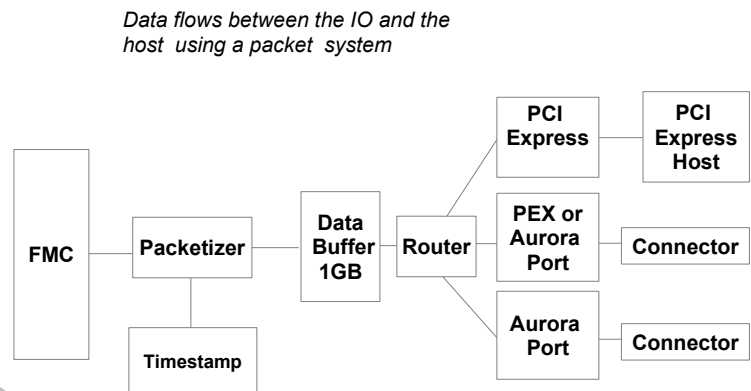

Example PEX6-COP Architecture

# PEX6-COP

and host interfaces, allowing complete customization of the functionality. Logic utilization is typically <10% of the device.

## Communications Interfaces

The PEX6-COP host interface features high performance PCI Express and Aurora ports. These ports allow the PEX6-COP to be used in many system topologies, including private data channels between cards.

The PCIe and Aurora ports are integrated with the Velocia packet system, a powerful data network that efficiently handles data transfers between multiple, independent data sources on the PEX6-COP and the host processor or other cards. Data is packetized, using packet sizes from 32 bytes to 128KB per packet, stamped with a packet ID and destination, and are then easily routed to other devices in the system. The Velocia packet system is completely defined by the logic firmware, giving complete flexibility to create any packet routing necessary to meet system latency and transfer rate requirements.

A set of logic components for packets is provided in the FrameWork Logic including packetizer, depacketizer, router and buffer memory controls. Packetizing includes timestamping per VITA 49. Data within the packets may be any format.

## Secondary Ports and Digital IO

The PEX6-COP family has high speed serial data links for multi-card system interconnects. These data ports, using protocols such as Aurora, provide low-latency direct or switched fabric connections to the system fabric. The ports enable the PEX6-COP to integrate with other PEX6 cards or peripherals to create powerful computing and signal processing architectures. Maximum data rates, with deterministic performance can be implemented in performance-driven systems using little or no protocol.

The secondary data port consists of x4 lanes that may be used as 4 x1 ports, or other configurations such as 2 x2, or 1 x4. For ease of use and purchasing, SATA300 cables and connectors are used on the card supporting up to 3.2Gbps data rates full duplex on each lane.

The digital IO has 32 digital lines, routed as matched differential pairs, connected to the FPGA. An MDR68 connector on the card rear pins out these DIO connections. Supported IO standards include LVCMOS25 and LVDS25.

## Card Management Features

The PEX6-COP has power and health monitoring to protect the system from card failure. Independent monitoring of the FPGA die temperature can shut down the card to prevent damage from overheating. The card also has over-current protection that disconnects system power in case of failure. The FPGA also has watchdog timer functionality that may be used to prevent runaway operation.

## FPGA Configuration

The module uses a FLASH memory for the Virtex 6 FPGA image. This FLASH can be programmed in-system using a software applet. There are two images in the FLASH: an application image and a “golden” image as a backup.

*Real-time system architectures are enabled using Velocia packet system in VPX systems*

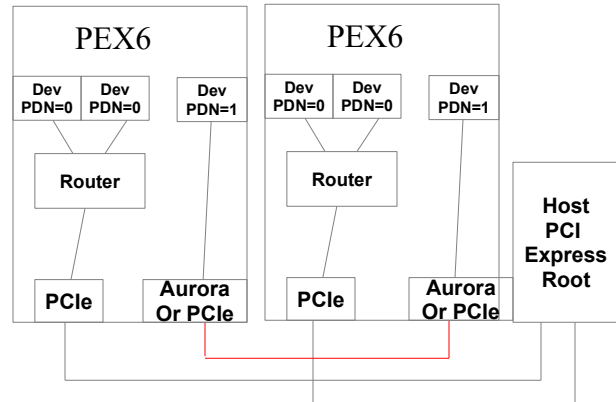

## Example System Topology:

PCIe bus with private Aurora channel

# PEX6-COP

During development, the JTAG interface to the FPGA is used for development tools such as ChipScope and MATLAB. This allows the FPGA image to be downloaded over the cable for debugging and test. The FPGA JTAG connector is compatible with Xilinx Platform USB Cable.

## Software Tools

Software development tools for the module provides comprehensive support including device drivers, data buffering, card controls, and utilities that allow developers to be productive from the start. At the most fundamental level, the software tools deliver data buffers to your application without the burden of low-level real-time control of the cards. Software classes provide C++ developers a powerful, high-level interface to the card that makes real-time, high speed data acquisition easier to integrate into applications.

Software for data logging and analysis are provided with every module. Data can be logged to system memory at full rate or to disk drives at rates supported by the drive and controller. Triggering and sample rate controls allow you to use the module's performance in your applications without ever writing code. Innovative software applets include *Binview* which provides data viewing, analysis and import to MATLAB for large data files.

Support for the Microsoft, Embarcadero and GNU C++ toolchains is provided. Supported OSes include Windows and Linux. For more information, the software tools User Guide and on-line help may be downloaded.

## Logic Tools

High speed DSP, analysis, customized triggering and other unique features may be added by modifying the logic. The FrameWork Logic tools provide support for RTL and MATLAB developments, providing the basic hardware interfaces, data paths and controls. The standard logic provides a hardware interface layer that allows designers to concentrate on the application-specific portions of the design. Designer can build upon the Innovative components for packet handling, hardware interfaces and system functions, the Xilinx IP core library, and third party IP. RTL source for the FrameWork Logic is provided for customization. Each design is provided as a Xilinx ISE project, with a ModelSim testbench illustrating logic functionality.

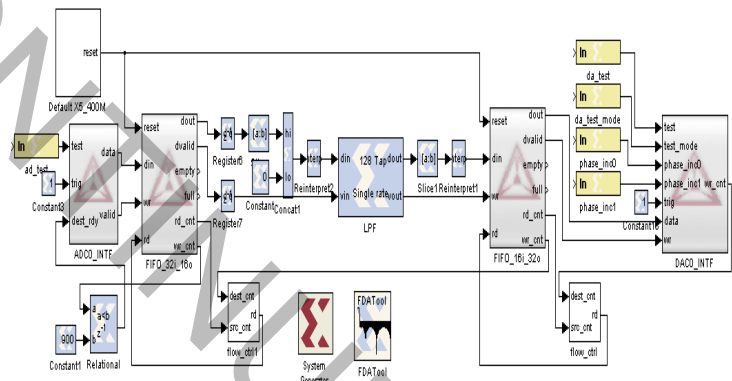

Using MATLAB Simulink for Logic Design

The MATLAB Board Support Package (BSP) allows logic development using Simulink and Xilinx System Generator. These tools provide a graphical design environment that integrates the logic into MATLAB Simulink for complete hardware-in-the-loop testing and development. This is an extremely power design methodology, since MATLAB can be used to generate, analyze and display the signals in the logic real-time in the system. Once the development is complete, the logic can be embedded in the FrameWork logic using the RTL tools.

The FrameWork Logic User sales brochure and User Guide more fully detail the development tools.

## IP for Virtex6 FPGA

Innovative provides many IP cores for signal processing functions such as up/down-conversion, modulation/demodulation, OFDM receiver and transmit to name a few.

The DDC channelizers are offered in channel densities from 4 to 256. The four channel DDC offers complete flexibility and independence in the channels, while the 128 and 256 channel cores offer higher density for uniform channel width applications. The DDC cores are highly configurable and include programmable channel filters, decimation rates, tuning and gain controls. An integrated power meter allows the DDC to measure any channel power for AGC controls. Multiple cores

# PEX6-COP

can be used for higher channel counts.

Each IP core is provided with a MATLAB simulation model that shows bit-true, cycle-true functionality. Signal processing designers can then use this model for channel design and performance studies. Filter coefficients and other parameters from the MATLAB simulation can be directly loaded to the hardware for verification.

Part Number	IP Core	Channels	Tuning	Decimation	Max Bandwidth	Channel Filter
58014	IP-MDDC4	4	$F_s/2^{32}$	16 to 32768	$F_s/16$	Programmable 100 tap filter
58015	IP-MDDC128	128	$F_s/2^{32}$	512 to 16384	$F_s/512$	Programmable 100 tap filter
58528	IP-DDC256	256	$F_s/2^{32}$	512 to 16384	$F_s/512$	Programmable 100 tap filter

Signal processing cores for communications applications are available for Virtex6.

Part Number	IP Core	Features
58001	PSK Demodulation	$N=2,4,8,\pi/4$ . Integrated carrier tracking and bit decision. Data rate to 160 Mbps.
58018	PSK Modulator	$N=2,4,8,\pi/4$ . Data rates up to 160 Mbps.
58002	FSK Demodulation	Coherent demodulation with carrier recovery,
58019	FSK Modulator	FSK modulation/
58020	QAM Modulator	Quadrature Amplitude Modulator.
58003	TinyDDS	Tiny DDS, 1/3 to 1/2 size of Xilinx DDS with equal SFDR, clock rates to 400 MHz with flow control
58011	XLFFT	IP core for 64K to 1M FFTs with windowing functions.
58012	Windowing	IP core for Hann, Blackman and uniform data windowing functions.
58013	CORDIC	IP core for sine/cosine generation using CORDIC method, resulting in 1/3 logic size of standard DDS cores.
58030	MDUC128	128-channel digital upconverter.
58036	DUC	Up-conversion with interpolation rates from 2-32K, programmable filters and tuning

## OFDM and LTE Cores

58029	OFDM Transmitter	OFDM transmit with IFFT, Windowing, Filtering, Cyclic Prefix and Upsample.
58031	OFDM Receiver	OFDM receiver with synchronization, downconversion and channel filtering.
58032	LTE Downlink Transmitter	LTE downlink transmitter core for FDD mode.

# PEX6-COP

58033	LTE Uplink Receiver	LTE uplink receiver core for FDD mode includes 2K FFT, timing and frame synchronization using ML estimation method, decoding of SSS and PSS signals for cell ID and frame sync.
-------	---------------------	---

## IMPORTANT NOTICES

Interconnect Systems International, LLC reserves the right to make corrections, modifications, enhancements, improvements, and other changes to its products and services at any time and to discontinue any product or service without notice. Customers should obtain the latest relevant information before placing orders and should verify that such information is current and complete. All products are sold subject to Interconnect Systems International, LLC 's terms and conditions of sale supplied at the time of order acknowledgment.

Interconnect Systems International, LLC warrants performance of its hardware products to the specifications applicable at the time of sale in accordance with Interconnect Systems International, LLC 's standard warranty. Testing and other quality control techniques are used to the extent Interconnect Systems International, LLC deems necessary to support this warranty. Except where mandated by government requirements, testing of all parameters of each product is not necessarily performed.

Interconnect Systems International, LLC assumes no liability for applications assistance or customer product design. Customers are responsible for their products and applications using Interconnect Systems International, LLC products. To minimize the risks associated with customer products and applications, customers should provide adequate design and operating safeguards.

Interconnect Systems International, LLC does not warrant or represent that any license, either express or implied, is granted under any Interconnect Systems International, LLC patent right, copyright, mask work right, or other Interconnect Systems International, LLC intellectual property right relating to any combination, machine, or process in which Interconnect Systems International, LLC products or services are used. Information published by Interconnect Systems International, LLC regarding third-party products or services does not constitute a license from Interconnect Systems International, LLC to use such products or services or a warranty or endorsement thereof. Use of such information may require a license from a third party under the patents or other intellectual property of the third party, or a license from Interconnect Systems International, LLC under the patents or other intellectual property of Interconnect Systems International, LLC .

Reproduction of information in Interconnect Systems International, LLC data sheets is permissible only if reproduction is without alteration and is accompanied by all associated warranties, conditions, limitations, and notices. Reproduction of this information with alteration is an unfair and deceptive business practice.

Interconnect Systems International, LLC is not responsible or liable for such altered documentation. Resale of Interconnect Systems International, LLC products or services with statements different from or beyond the parameters stated by Interconnect Systems International, LLC for that product or service voids all express and any implied warranties for the associated Interconnect Systems International, LLC product or service and is an unfair and deceptive business practice. Interconnect Systems International, LLC is not responsible or liable for any such statements.

For further information on Interconnect Systems International, LLC products and support see our web site:

**[www.isipkg.com](http://www.isipkg.com)**

Mailing Address:

Interconnect Systems International, LLC, Inc.

741 Flynn Road, Camarillo, CA 93012